

Chain Pallet Conveyor System

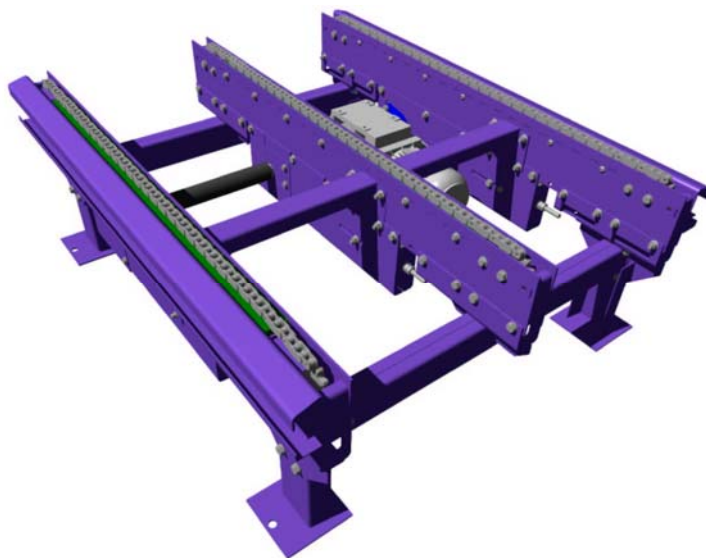

3/4" pitch flat sided linked chain provides a strong supporting surface to convey pallets up to 1500kg. These modules are available in two and three chain versions. Chain tensioning is quick and easy with no requirement to remove any guards.

- **1500kg pallet load capacity**
- **4 – mm thick side channels**
- **3/4" pitch flat sided chain on low friction polymer guide strips**
- **Side channels can be used as cable ways**
- **Chain in the same lateral position on all modules.**
- **Hollow cross ties to enable cabling to cross from one side to the other.**

Heights

Range of heights available from 375 - 925mm (Top of Chain)

Motor

0.75, 1.1, 1.5, 2.2, and 3.0 kW available

Motor Types

- No Brake - No Inverter
- No Brake - Soft Start
- No Brake - Inverter
- No Brake - Soft Start Reversing
- Braked - No Inverter
- Braked - Soft Start
- Braked - Inverter
- Braked - Soft Start Reversing

Chain

3/4" pitch simplex chain

Lengths Available

1300, 1500, 2050, 2450, 3000 and 3600mm

Pallets

1200mm L-R

Speeds

12m/min and 18m/min available

Electrical Power

Motors should be connected to 400/415V 3-phase, 50Hz supply.

12m/min	Motor Power (kW)	Full Load Current(A)
	0.75	2.0
	1.5	4.2
2.2	5.9	
18m/min	Motor Power (kW)	Full Load Current(A)
	1.1	3.2
	2.2	5.9
	3.0	7.2

